

User Manual

G Sub 1201 dp+



Version 3.5

07.10.2022

SEEBURG
acoustic line

1 Contents

1	Contents	2
2	Foreword.....	3
3	Safety instructions.....	4
4	Connectors/Indicators.....	6
4.1	Connection panel.....	6
4.2	Connectors	7
4.3	Controls.....	9
4.4	Status indication.....	9
5	Operation	10
5.1	Starting up.....	10
5.2	Selecting a bank	10
5.3	Setting level	11
5.4	Recalling presets	11
5.4.1	Preset Bank 1 – Default Settings.....	11
5.4.2	Preset Bank 2 – L-series	12
5.4.3	Preset Bank 3 – i-series.....	12
5.5	Reprogramming of dp-speakers with preset audio files.....	13
5.6	Locking the buttons	13
5.7	Cardioid Mode.....	14
6	Technical specifications	16
7	Declaration of conformity	17

2 Foreword

The G Sub 1201 dp+ is a multi-functional premium class subwoofer with an integrated digital amplifier providing 2x 800 Watt @ 4 Ohm (AES) and a DSP controller. The 12" long-excursion driver is powered by one of the amplifier channels, and the other channel is available to power external passive loudspeakers connected to the SpeakON out connector. According to requirements, mid-high systems (e.g. TS Nano or i4) or an additional subwoofer (e.g. G Sub 1201) can be connected. Various pre-configured presets and level settings are available for selection.

The integrated DSP controller is based on the same operating principle as the stand-alone controllers HDLM 8 and DSP 2.6. A mere 0.8 ms latency (from analogue input to output) is achieved through the use of a 96 kHz sample rate. The excellent signal to noise ratio is a further feature of the DSP controller. Electronic simulation of a transformer balanced input provides additional protection against hum and buzz caused for example by external interference. High grade electronic components from the industrial sector and first-class circuit design result in a robust device with excellent audio characteristics and minimize disruptive noise.

The default state of the integrated DSP controller is the standard configuration as described in this manual. Custom presets can be installed by the user, but must be programmed with the LPI (Loudspeaker Programming Interface) by the manufacturer. The preset file is a custom audio file which is simply played into the audio input of the controller. In this manner, individual configurations can be created, for instance to accommodate the specific requirements of an installation project. Furthermore, should you ever be unsure as to the integrity of the DSP configuration of your controller, you can obtain a fresh default file from SEEBURG acoustic line and re-install the original factory presets yourself. Efficient and intelligent limiter functions provide optimal protection without sacrificing any of the potential of the system.

If you would like further information about SEEBURG acoustic line products, or have any comments or suggestions regarding this handbook or the product, you can contact us here:

SEEBURG acoustic line Produktions- und Vertriebsgesellschaft mbH

Auweg 32

89231 Senden

07307 / 9700 – 0

www.seeburg.com

info@seeburg.net

3 Safety instructions



Acoustic

Even a low input level can result in a sound pressure level at the loudspeaker which can be damaging to your hearing. Do not remain in close proximity to the loudspeaker when it is being operated. Use hearing protection. Observe all relevant Health and Safety and Environmental Protection regulations.



Mechanical

Movable parts and falling objects during installation and de-rigging can cause serious injury. Observe at all times all relevant Health and Safety regulations and regulations on the installation and operation of PA systems.



Magnetic und electrical

Loudspeakers generate a magnetic field even without a source of power connected. This can damage or destroy magnetic storage devices. The PowerCon loop-through connector is under power when the device is in operation. Observe all relevant safety regulations at all times.



General safety precautions

The installation and de-rigging of this equipment should only be carried out by appropriately qualified and experienced personnel, and according to all relevant safety regulations. Find out about the applicable regulations in the country you work in and comply with the respective regulations.

Do not operate the loudspeaker if you have any doubts about the safety of doing so, or if the loudspeaker shows any signs of faulty operation. There are no user serviceable parts inside the device. For repairs, contact your dealer or a qualified service technician.

The loudspeaker is a class 1 device requiring a 230 V / 50 Hz power connection with earth contact.

If the loudspeaker is connected to a power source in which the voltage is too high, a protective mechanism is triggered which reliably safeguards the amplifier module and DSP. Once triggered, the protection must be renewed by a qualified service technician.

Never open the housing. There are no user serviceable parts inside. Do not expose the loudspeaker to rain, and avoid operating in environments below -5°C or above 40°C . Be aware of the possibility of condensation forming inside the housing due to rapid changes in temperature. Allow the loudspeaker to adjust to ambient temperature before operation. Leave the device switched on if operating in unfavorable conditions.

To prevent overheating, do not operate the loudspeaker in the direct vicinity of strong heat sources, and avoid direct sunlight. After long periods of operation, the loudspeaker, particularly metallic components such as the pole mount and the connector panel, can reach temperatures exceeding 40°C .

4 Connectors/Indicators

4.1 Connection panel

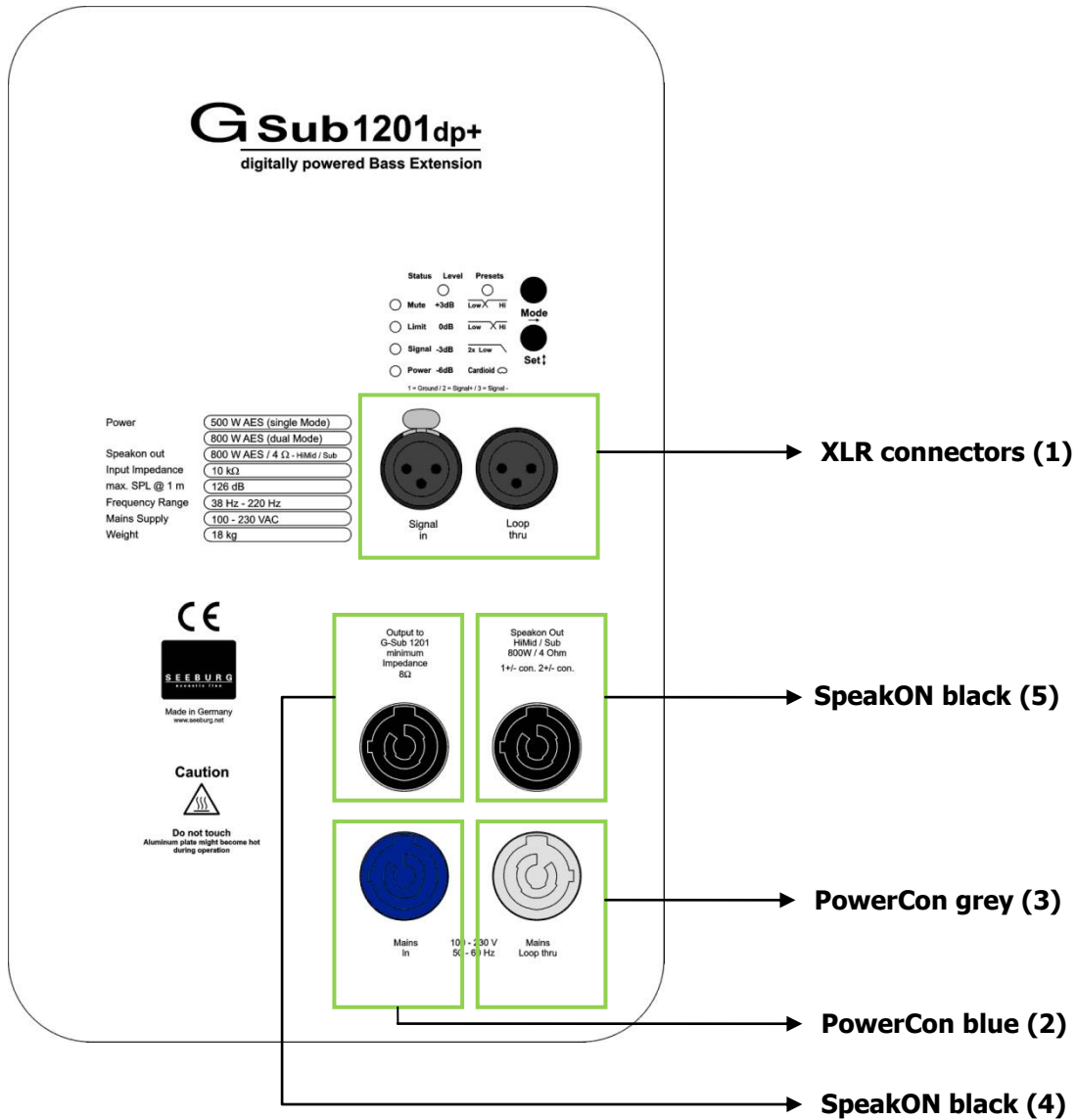

4.2 Connectors

XLR connectors (1)

The G Sub 1201 dp+ should be connected with a standard symmetrically wired XLR cable. To connect the input signal to further devices, use the male XLR Loop thru connector. To obtain full power performance from the system, the signal source should be able to provide a minimum of 6 dBu distortion free output voltage.

PowerCon blue (2)

Power supply input voltage 110-230 VAC. This connector provides the function of an on-off switch. After powering on (turn the connector to the right until it locks), the systems starts up and is ready for use after approximately 3 seconds. Avoid repeatedly switching the system on and off, particularly when it is operating.

PowerCon grey (3)

110-230 VAC loop-through connector. This connector is to be used when multiple active loudspeakers are to be provided with power from one source. Please observe carefully the maximum power capacity of the power source.



The nominal power consumption of the G Sub 1201 dp+ under full power is 2.0 A (measured with pink noise, Crest Factor 8). Transient peaks can, however, cause much higher momentary power drain. Observe carefully the nominal power consumption when connecting the loudspeaker(s) to the power source, and observe carefully the cut-off current of the safety circuit breakers. We recommend using the loudspeaker on power circuits with circuit breakers with C characteristic.

SpeakON black (4) – Parallel LS output

This connector is used to connect and power a further external G Sub 1201 from the first amplifier channel parallel to the built in loudspeaker (pin assignment 2+/-). The output signal from the second amplifier channel is present here on pins 1+/- to enable the implementation of system cabling.

ATTENTION! The total impedance of the connected passive systems must be 8 Ohm or more! It is highly recommended to not connect more than one passive G Sub 1201 to this output.

SpeakON black (5)

This connector is used to connect additional passive loudspeakers to the second amplifier channel. Presets are available for selection for various high-mid systems (e.g. i4, L16, TS Nano or TSM8) or two additional G Sub 1201 units (switch to Bi-Amp mode). The output signal from the second amplifier channel is present on both 2+/- and 1+/-.

ATTENTION! The total impedance of the connected loudspeakers must be 4 Ohm or more. When the preset “2 x Low” is selected, no more than 2 passive G Sub 1201 units should be connected. When a “Low-Hi” preset is selected, only mid-high systems should be connected.

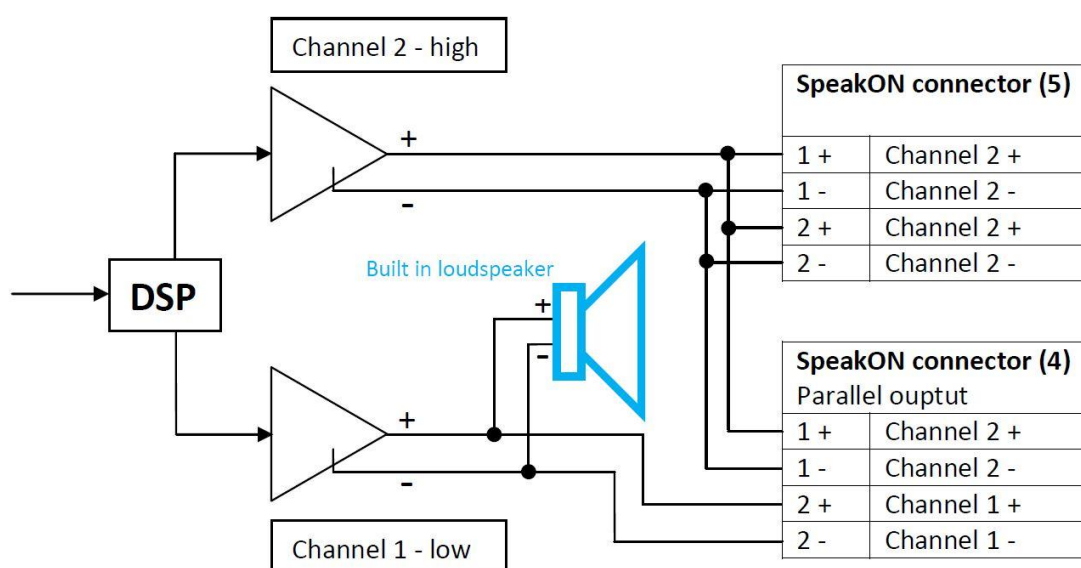

4.3 Controls

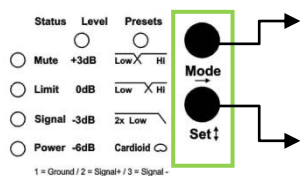

Mode button:

Switch between the modes Status / Level and Presets.

Set button:

Set various values and Mute on/off..

4.4 Status indication

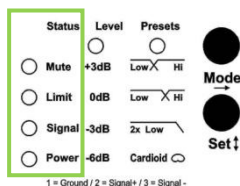

Mute LED:

Lights red when the system is muted (press the Set button in Status Mode), or in technically critical conditions.

Limit LED:

Lights yellow when the limiter is limiting one or more amplifier channels.

Signal LED:

Lights green when a signal of more than -20 dBu is present. The LED still lights up when the system is muted.

Power LED:

Lights when the system is powered up.

5 Operation

5.1 Starting up

When the system is switched on, it retains the settings from the previous usage. This also applies to the Bank selection. The system is then in the Status Mode . If the red Mute LED is lit as a result of the previous setting, no signal will be passed. Pressing the Set button once will un-mute the system. The Mute LED will go off, and signal will be passed.

5.2 Selecting a bank

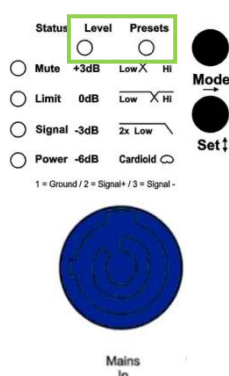

The loudspeaker presets are stored in the DSP controller in up to 3 banks. To change banks, press and hold the Mode button whilst the loudspeaker is switched on.

1. Press and hold the Mode button.
2. Connect the power cable (PowerCon blue).
3. Corresponding LEDs blink to indicate the chosen bank.
4. Release the Mode button.

When the power cable is connected, the level and/or preset LED lamps blink to indicate which bank is selected. The level LED blinks to indicate the first bank, the preset LED for the second. The third bank is indicated by both LEDs blinking.

If only one bank is programmed, there is no possibility to switch the bank.

Bank 1 – Default Settings	Bank 2 – L-series	Bank 3 – i-series
LP 120 Hz + HP 120 Hz	LP 120 Hz + L16	LP 120 Hz + i5
LP 160 Hz + HP 160 Hz	LP 160 Hz + L8	LP 160 Hz + i4
2x LP 120 Hz	2x LP 120 Hz	2x LP 120 Hz
Switchable Cardioid Mode	Switchable Cardioid Mode	Switchable Cardioid Mode

5.3 Setting level

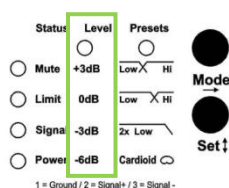

Pressing the Mode button once selects the Level Mode, in which you can adjust the output volume in 3 dB steps. There are four settings available: +3 dB, 0 dB (standard), -3 dB and -6 dB. The setting is done by pressing the Set button. The Level LED lights to indicate which mode is activated. The four vertically aligned LEDs (lit green in this mode) indicate which setting is selected.

ATTENTION! The level settings apply only to the first amplifier channel which powers the in-built loudspeaker and the parallel LS output (SpeakON socket (4)).

5.4 Recalling presets

Pressing the Mode button twice selects the Preset Mode. Three different presets with an each switchable Cardioid Mode are available in each bank for selection via the Set button. The four vertically aligned LEDs indicate the current selection. The Cardioid Mode is activated in the preset when the bottom of the four vertical LEDs lights up.

5.4.1 Preset Bank 1 – Default Settings

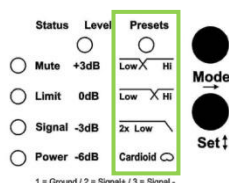

Low --- Hi:

Preset for use when the second amplifier channel is powering a mid-high system (e.g. A4 or TSM8) connected to SpeakON socket (5). The acoustical cross-over frequency in this preset is approx. 120 Hz.

Low --- Hi:

Preset with a higher cross-over frequency for use when the second amplifier channel is powering a smaller mid-high system (e.g. A1 or TS Nano) connected to SpeakON socket (5). The cross-over frequency in this preset is approx. 160 Hz.

2x Low:

Preset for use when the second amplifier channel is powering further passive G Sub 1201 units (max. 2 units) connected to SpeakON socket (5).

Cardioid Mode:

The so-called backward attenuation of a subwoofer system (combination of at least 2x subwoofers) can be significantly increased with a cardioid. The cardioid function works regardless of the choice of three possible presets. If this mode is activated, the G Sub 1201 dp+ and the subwoofer connected to the parallel LS output are in Cardioid Mode. The connection does not change the SpeakON socket (5) what means that up to two passive front-facing G Sub 1201 can be connected (when using the 2x low preset). More details in section 5.7.

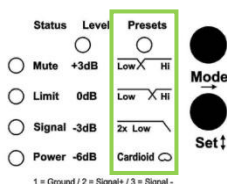
5.4.2 Preset Bank 2 – L-series**Low --- Hi:**

Preset for use when the second amplifier channel is powering an L16i/j system connected to SpeakON socket (5).

Low --- Hi:

Preset for use when the second amplifier channel is powering an L8i/j system connected to SpeakON socket (5).

2x Low:

Preset for use when the second amplifier channel is powering further passive G Sub 1201 units (max. 2 units) connected to SpeakON socket (5).

Cardioid Mode:

See the description for Preset Bank 1.

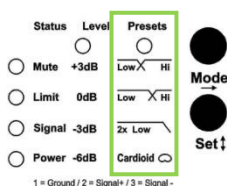
5.4.3 Preset Bank 3 – i-series**Low --- Hi:**

Preset for use when the second amplifier channel is powering an i5 system connected to SpeakON socket (5).

Low --- Hi:

Preset for use when the second amplifier channel is powering an i4 system connected to SpeakON socket (5).

2x Low:

Preset for use when the second amplifier channel is powering further passive G Sub 1201 units (max. 2 units) connected to SpeakON socket (5).

Cardioid Mode:

See the description for Preset Bank 1.

5.5 Reprogramming of dp-speakers with preset audio files

By default, the built-in DSP controller is in a default configuration state that conforms to the description in the User Manual. The installation of special presets on the DSP controller can be done by the user himself, since only a special preset audio file must be loaded. The programming of these audio files via the LPI (Loudspeaker Programming Interface) can only be done by the manufacturer.

The preset is getting installed on the DSP by playing the preset audio file in the XLR input. This can be done in different ways (MP3 player, smart phone, PC, CD player, ...). Installation via PC is done as follows:

1. Use a mini-jack-XLR (stereo) cable to connect the headphone output to the XLR input of the self-powered box. Use only one of the XLR connectors.
2. Mute the box by pressing the Set button in Status Mode. The Mute LED lights up. The DSP controller can only receive data in the muted state.
3. Make sure your computer's volume is set to 100%.
4. Load the ".wav" file received from SEEBURG acoustic line into a music player.
5. Press the play button.
6. After a successful programming operation, the Mute LED turns off.



It is very important to ensure that the preset audio file is played in single mode. Other music files in the playlist or on the data storage medium will otherwise be played at full volume.

5.6 Locking the buttons

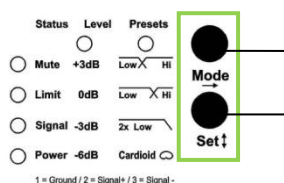

Press and hold the Set and Mode buttons simultaneously for more than 3 seconds to lock the controls of the system. Repeat the action to unlock the system.

5.7 Cardioid Mode

The Cardioid Mode serves to generate a cardioid response pattern for the subwoofers. Using this mode, a significant reduction in bass energy emission to the rear of the system can be achieved. A minimum of 2 subwoofer units is required. Multiples of three is better. Specialised signal processing creates controlled interference patterns between the sources, leading to the desired cancellation to the rear.

In order for the interaction between the sources to function correctly and generate the desired cardioid response, the subwoofer system must be set up at least 1.5 m away from any bordering surface such as a wall or solid stage front.

Installation using two subwoofers:

The G Sub 1201 dp+ that is in Cardioid Mode must be positioned such that the front of the unit is facing the rear, whilst a second G Sub 1201 dp+ which is not in Cardioid Mode faces the front as normal. The level of the rear-facing G Sub 1201 dp+ must be reduced by 6 dB compared to the front-facing subwoofer if the cardio system consists of only two subwoofers.

Note:

Both subwoofers must be set to the same cut-off frequency. The cardioid preset of rear-facing subwoofer must be activated and the level has to be reduced by 6 dB.

Application example:

Only the rear-facing subwoofer is operated in Cardioid Mode. This applies regardless of whether the two units are stacked on top of each other or laid side by side on the ground.

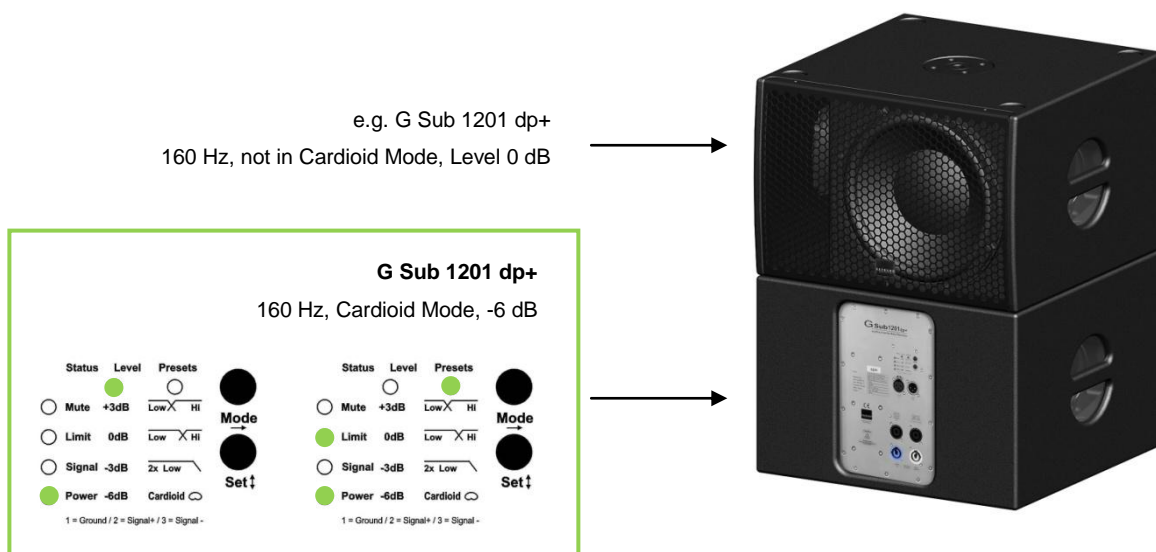

Installation using three subwoofers (recommended):

The performance of the cardioid configuration is better when 3 subwoofers are used together. The units can be stacked on top of each other or laid side by side on the ground. If in a stack, the lowest unit should face the rear. If laid side by side, the middle unit faces the rear.

As in the previous example with two subwoofers, the rearwards facing subwoofer is operated in Cardioid Mode. The two forwards facing units are operated as normal without the Cardioid Mode activated (e.g. one G Sub 1201 dp+ with a passive G Sub 1201 connected to the parallel output SpeakON (4) and the Cardioid Mode not selected). All of the subwoofers in the configuration should be operating at the same level and with the same cut-off frequency to get the best result.

Note:

Both subwoofers must be set to the same cut-off frequency. The cardioid preset of rear-facing subwoofer must be activated.

Application example:

Only the rear-facing subwoofer is operated in Cardioid Mode. This applies regardless of whether the two units are stacked on top of each other or laid side by side on the ground.

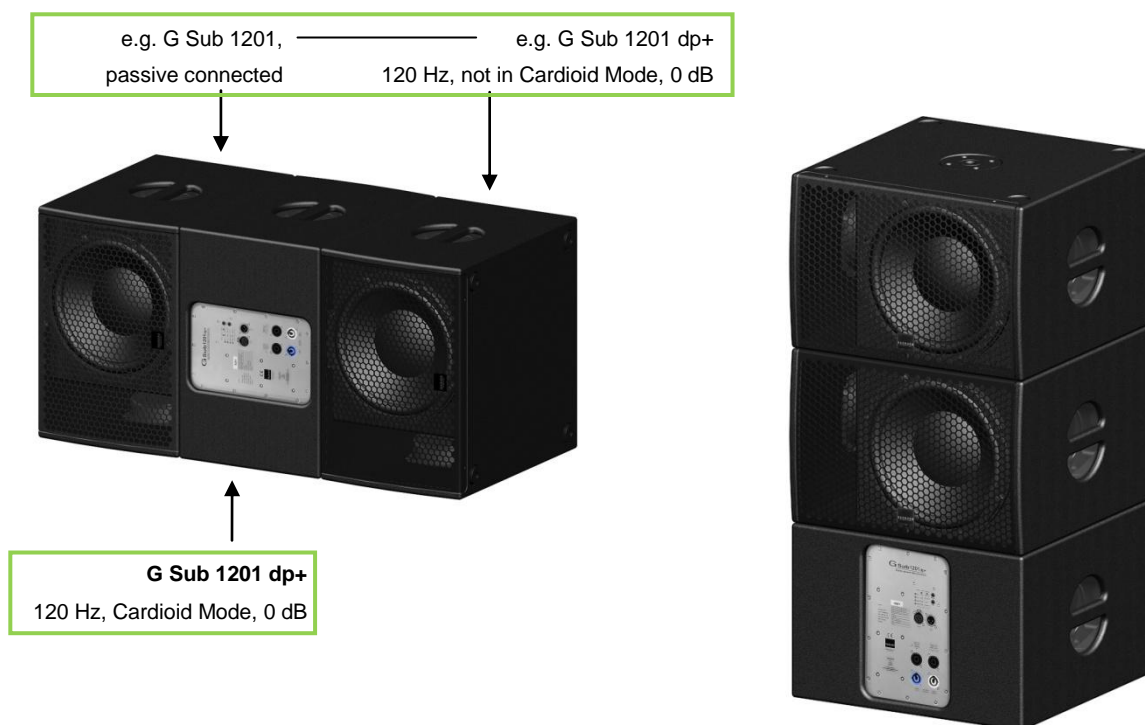

6 Technical specifications

Speaker Components	12" Nd
Description	Digitally Powered Bass Extension
Amp Power	500 W AES (single Mode) / 110-230 V 800 W AES (dual Mode) / 110-230 V 800 W AES / 4 Ω - HiMid/Sub
Rated Current	2 A @ 230 V
SPL (Peak @ 1m)	131 dB
Max. Input Signal	25 dBu
DSP	HDLM FPGA Processing 32 bit floating point
AD / DA	24 bit / 96 kHz
Latency	0,8 ms (analog in to analog out)
Usable Range (-6dB)	40 Hz - 120 / 140 Hz
Tuning Frequency Excursion minimum	47 Hz
Connectors	Neutrik XLR in/out Neutrik PowerCon in/out 2x Neutrik Speakon NL4MP out
Handles	2 x
Rigging / Fittings	M20 on top
Weight	18,0 kg
Size height x width x depth	33,0 x 48,5 x 48,5 cm
Order No.	00610/dp

The technical data sheet and further information about possible applications for the system and available accessories can be downloaded at the following Internet address:

http://www.seeburg.net/download_getfile.php?file=downloads/06-Datenblaetter/G-Subwoofer/G-Sub-1201-dp-plus_Datenblatt_dt.pdf



This manual applies only to systems fitted with the *DPLM*-DSP Controller.

The version fitted with the *DPLM*-DSP Controller can be identified by the control panel located above the XLR connectors.

7 Declaration of conformity

EG Declaration of conformity

This product

G Sub 1201 dp+

confirms to the following EU guidelines, including any additions:

- ✓ 2006/95/EG, Low Voltage
- ✓ 2004/108/EG, Electromagnetic Compatibility
- ✓ (Locations: Appendix 1, Paragraph 1, a and b)

The following standards have been applied:

- ✓ DIN EN 60065
- ✓ DIN EN 55103-1:1996, classes E1 to E4
- ✓ DIN EN 55103-2:1996, classes E1 to E4

Declared by: Winfried Seeburg, SEEBURG acoustic line GmbH

Place and date: Senden, 01.01.2010

Legally binding sign: _____

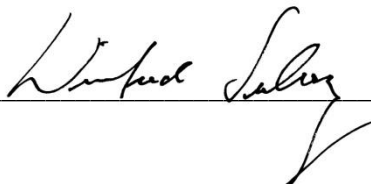

The attachments constitute part of this declaration. This declaration certifies conformity with the listed guidelines, but does not guarantee any product characteristics. The safety precautions listed in the product documentation must be observed.

SEEBURG acoustic line Produktions- und Vertriebsgesellschaft mbH

Auweg 32

89231 Senden

07307 / 9700 – 0

Benutzerhandbuch / User Manual

Irrtum bei Beschreibung
sowie technische
Änderungen vorbehalten.

Alle SEEBURG acoustic line
Produkte sind nur für den
gewerblichen Einsatz bestimmt.

All specifications are
current at the time of publishing
but are subject to change.

SEEBURG acoustic line
Produktions- und Vertriebs GmbH

Auweg 32
D-089250 Senden-Freudenegg

Fon: +49 (0)7307 97 00- 0
Fax: +49 (0)7307 97 00- 29

www.seeburg.com
info@seeburg.net