

User Manual

G Sub 1201 dp++



Version 3.1

18.05.2020

SEEBURG
acoustic line

1 Contents

1	Contents	2
2	Foreword.....	3
3	Safety instructions.....	4
4	Connectors/Indicators.....	6
4.1	Connection panel.....	6
4.2	Connectors	7
4.3	Controls	9
4.4	Status indication.....	9
5	Operation	10
5.1	Starting up.....	10
5.2	Selecting a bank	10
5.3	Setting level	11
5.4	Recalling presets	12
5.4.1	Preset Bank 1 – Default Settings.....	13
5.4.2	Preset Bank 2 – L-series	14
5.4.3	Preset Bank 3 – i-/GL-series	14
5.5	Reprogramming of dp-speakers with preset audio files.....	15
5.6	Locking the buttons	15
6	Application examples.....	16
6.1	Application example 1	16
6.2	Application example 2.....	17
6.3	Application example 3.....	18
7	Technical specifications	19
8	Declaration of conformity	20

2 Foreword

The G Sub 1201 dp++ is a multi-functional premium class subwoofer with an integrated digital amplifier providing 1x 1000 Watt at 2x 500 Watt @ 4 Ohm (AES) and a DSP controller. The 12" long-excursion driver is powered by one of the amplifier channels, and the other two channels are available to power external passive loudspeakers connected to the SpeakON out connectors. According to requirements, mid-high systems (e.g. X2, i5 or A2) and an additional subwoofer (e.g. G Sub 1201) can be connected. Various pre-configured presets and level settings are available for selection.

The integrated DSP controller is based on the same operating principle as the stand-alone controllers HDLM 8 and DSP 2.6. A mere 0.8 ms latency (from analogue input to output) is achieved through the use of a 96 kHz sample rate. The excellent signal to noise ratio is a further feature of the DSP controller. Electronic simulation of a transformer balanced input provides additional protection against hum and buzz caused for example by external interference. High grade electronic components from the industrial sector and first-class circuit design result in a robust device with excellent audio characteristics and minimize disruptive noise.

The default state of the integrated DSP controller is the standard configuration as described in this manual. Custom presets can be installed by the user, but must be programmed with the LPI (Loudspeaker Programming Interface) by the manufacturer. The preset file is a custom audio file which is simply played into the audio input of the controller. In this manner, individual configurations can be created, for instance to accommodate the specific requirements of an installation project. Furthermore, should you ever be unsure as to the integrity of the DSP configuration of your controller, you can obtain a fresh default file from SEEBURG acoustic line and re-install the original factory presets yourself. Efficient and intelligent limiter functions provide optimal protection without sacrificing any of the potential of the system.

If you would like further information about SEEBURG acoustic line products, or have any comments or suggestions regarding this handbook or the product, you can contact us here:

SEEBURG acoustic line Produktions- und Vertriebsgesellschaft mbH

Auweg 32

89231 Senden

07307 / 9700 – 0

www.seeburg.com

info@seeburg.net

3 Safety instructions



Acoustic

Even a low input level can result in a sound pressure level at the loudspeaker which can be damaging to your hearing. Do not remain in close proximity to the loudspeaker when it is being operated. Use hearing protection. Observe all relevant Health and Safety and Environmental Protection regulations.



Mechanical

Movable parts and falling objects during installation and de-rigging can cause serious injury. Observe at all times all relevant Health and Safety regulations and regulations on the installation and operation of PA systems.



Magnetic und electrical

Loudspeakers generate a magnetic field even without a source of power connected. This can damage or destroy magnetic storage devices. The PowerCon loop-through connector is under power when the device is in operation. Observe all relevant safety regulations at all times.



General safety precautions

The installation and de-rigging of this equipment should only be carried out by appropriately qualified and experienced personnel, and according to all relevant safety regulations. Find out about the applicable regulations in the country you work in and comply with the respective regulations.

Do not operate the loudspeaker if you have any doubts about the safety of doing so, or if the loudspeaker shows any signs of faulty operation. There are no user serviceable parts inside the device. For repairs, contact your dealer or a qualified service technician.

The loudspeaker is a class 1 device requiring a 230 V / 50 Hz power connection with earth contact.

If the loudspeaker is connected to a power source in which the voltage is too high, a protective mechanism is triggered which reliably safeguards the amplifier module and DSP. Once triggered, the protection must be renewed by a qualified service technician.

Never open the housing. There are no user serviceable parts inside. Do not expose the loudspeaker to rain, and avoid operating in environments below -5°C or above 40°C . Be aware of the possibility of condensation forming inside the housing due to rapid changes in temperature. Allow the loudspeaker to adjust to ambient temperature before operation. Leave the device switched on if operating in unfavorable conditions.

To prevent overheating, do not operate the loudspeaker in the direct vicinity of strong heat sources, and avoid direct sunlight. After long periods of operation, the loudspeaker, particularly metallic components such as the pole mount and the connector panel, can reach temperatures exceeding 40°C .

4 Connectors/Indicators

4.1 Connection panel

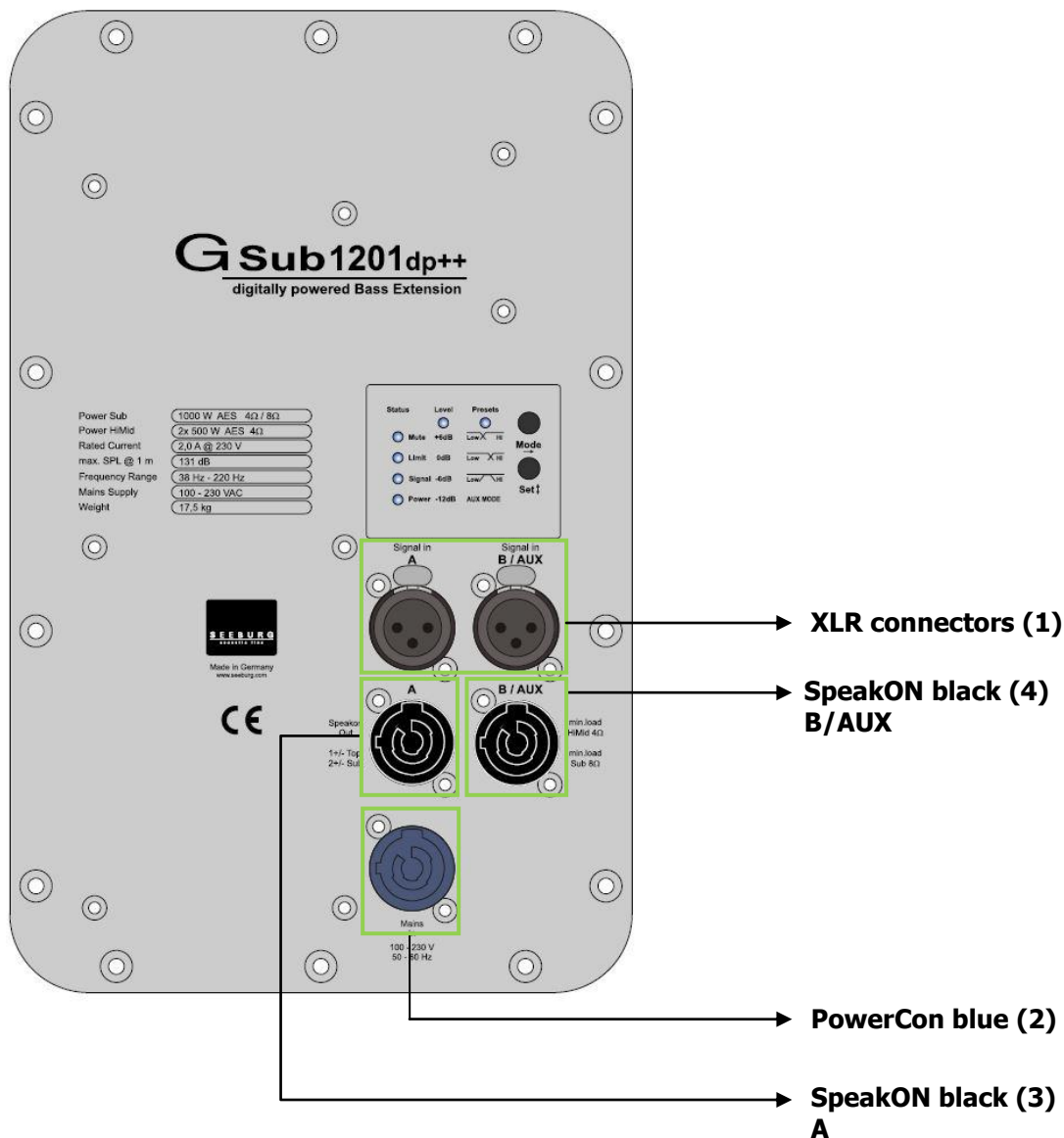

4.2 Connectors

XLR connectors (1)

The G Sub 1201 dp++ should be connected with a standard symmetrically wired XLR cable. To obtain full power performance from the system, the signal source should be able to provide a minimum of 6 dBu distortion free output voltage.

PowerCon blue (2)

Power supply input voltage 110-230 VAC. This connector provides the function of an on-off switch. After powering on (turn the connector to the right until it locks), the systems starts up and is ready for use after approximately 3 seconds. Avoid repeatedly switching the system on and off, particularly when it is operating.



The nominal power consumption of the G Sub 1201 dp++ under full power is 1.6 A (measured with pink noise, Crest Factor 8). Transient peaks can, however, cause much higher momentary power drain. Observe carefully the nominal power consumption when connecting the loudspeaker(s) to the power source, and observe carefully the cut-off current of the safety circuit breakers. We recommend using the loudspeaker on power circuits with circuit breakers with C characteristic.

SpeakON black (3) – Loudspeaker output A (left)

This connector is used to connect additional passive loudspeakers for the left side to the second amplifier channel. Depending on the loaded preset, various mid-high systems (e.g. A2, X2, i4, L16, etc.) can be connected (coding 1 +/-). The signal from the amplifier channel that powers the internal speaker is here at 2 +/- (system wiring). Therefore another G Sub 1201 (switch to Bi-Amp mode) can be connected to this socket.

ATTENTION! The total impedance of the loudspeakers additionally connected to this socket on 1 +/- must not be less than 4 ohms!

The total impedance of the loudspeaker additionally connected to 2 +/- must not be less than 8 ohms! It is strongly recommended to only connect a passive G Sub 1201 here.

If an additional G Sub 1201 is connected to 2 +/- of this socket, make sure that no further loudspeaker is connected to 2 +/- at SpeakON socket B / AUX (4).

SpeakON black (4) – Loudspeaker output B/AUX (right/monitor)

This connector is used to connect additional passive loudspeakers for the right side to the third amplifier channel. Depending on the loaded preset, various mid-high systems (e.g. A2, X2, i4, L16, etc.) can be connected (coding 1 +/-). The signal from the amplifier channel that powers the internal speaker is here at 2 +/- (system wiring). Therefore another G Sub 1201 (switch to Bi-Amp mode) can be connected to this socket.

ATTENTION! The total impedance of the loudspeakers additionally connected to this socket on 1 +/- must not be less than 4 ohms!

The total impedance of the loudspeaker additionally connected to 2 +/- must not be less than 8 ohms! It is strongly recommended to only connect a passive G Sub 1201 here.

If an additional G Sub 1201 is connected to 2 +/- of this socket, make sure that no further loudspeaker is connected to 2 +/- at SpeakON socket A (3).

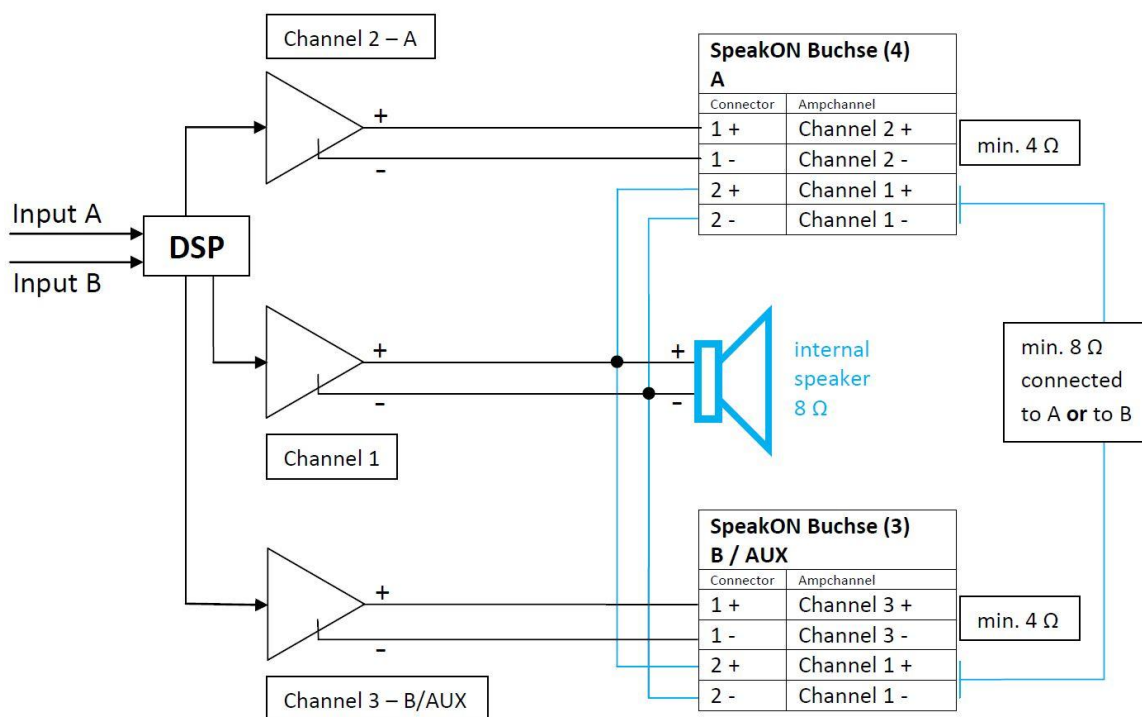

* Buchse (dt.) ≙ socket (engl.)

4.3 Controls

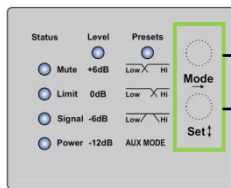

Mode button:

Switch between the modes Status / Level and Presets.

Set button:

Set various values and Mute on/off..

4.4 Status indication

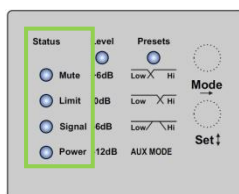

Mute LED:

Lights red when the system is muted (press the Set button in Status Mode), or in technically critical conditions.

Limit LED:

Lights yellow when the limiter is limiting one or more amplifier channels.

Signal LED:

Lights green when a signal of more than -20 dBu is present. The LED still lights up when the system is muted.

Power LED:

Lights when the system is powered up.

5 Operation

5.1 Starting up

When the system is switched on, it retains the settings from the previous usage. This also applies to the Bank selection. The system is then in the Status Mode. If the red Mute LED is lit as a result of the previous setting, no signal will be passed. Pressing the Set button once will un-mute the system. The Mute LED will go off, and signal will be passed.

5.2 Selecting a bank

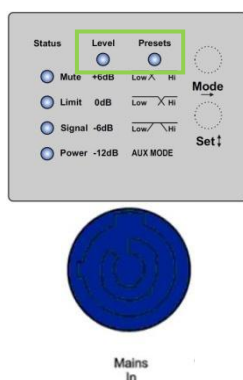

The loudspeaker presets are stored in the DSP controller in up to 3 banks. To change banks, press and hold the Mode button whilst the loudspeaker is switched on.

1. Press and hold the Mode button.
2. Connect the power cable (PowerCon blue).
3. Corresponding LEDs blink to indicate the chosen bank.
4. Release the Mode button.

When the power cable is connected, the level and/or preset LED lamps blink to indicate which bank is selected. The level LED blinks to indicate the first bank, the preset LED for the second. The third bank is indicated by both LEDs blinking.

If only one bank is programmed, there is no possibility to switch the bank.

Bank 1 – Default Settings	Bank 2 – L-series	Bank 3 – i-/GL-series
LP 120Hz + HP 120Hz	LP 120Hz + L-Serie HP 180Hz	LP 120Hz + i5
LP 160Hz + HP 160Hz	LP 160Hz + L-Serie HP 180Hz	LP 160Hz + i4
LP 160Hz + HP 120Hz	LP 120Hz + L-Serie +Low	LP 120Hz + GL-Serie xov
Switchable AUX mode	Switchable AUX mode	Switchable AUX mode

5.3 Setting level

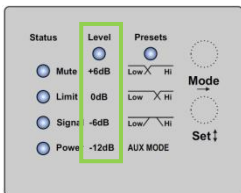

After switching on and starting up, the G Sub 1201 dp++ is in Status Mode . Pressing the Mode button once selects the Level Mode, in which you can adjust the output volume in 3 dB steps. Seven different values between +6 dB and -12 dB are available, with 0 dB being the standard setting. The setting is made using the Set button. The green LED above on the left indicates that you are in Level Mode, whereby the four vertically arranged LEDs (now lighting up green) indicate the respectively set value. If two adjacent LEDs light up, the intermediate value of the printed levels is set.

ATTENTION! The level settings apply only to the first amplifier channel which powers the in-built loudspeaker and the parallel LS output (2+/- of SpeakON sockets (3) and (4)).

Level setting options

	+ 6 dB		+ 3 dB
	0 dB		- 3 dB
	- 6 dB		- 9 dB
	- 12 dB		

5.4 Recalling presets

After switching on and starting up, the G Sub 1201 dp++ is in Status Mode . Pressing the Mode button twice to select the Preset Mode. Three different presets can be called up using the set button. The green LED above on the right indicates that you are in Preset Mode. The four vertical LEDs show the selected preset during the selection.

If the lower LED lights up in addition to one of the three LEDs above, the Soft Mode is activated.

The following representations show examples of settings when the first bank is active:

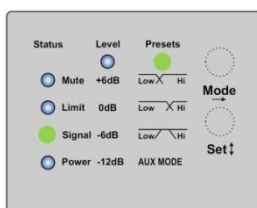

The preset “LP 160Hz + HP 120Hz” is active.

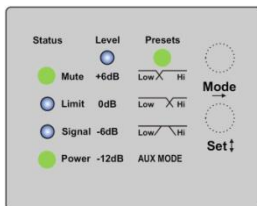

The preset “LP 160Hz + HP 120Hz” is active.

The AUX mode is switched on.

5.4.1 Preset Bank 1 – Default Settings

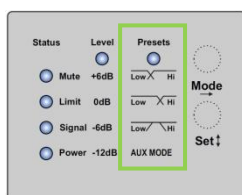

: **LP 120Hz + HP 120Hz:**

Preset for use when the second and third amplifier channels are powering mid-high systems (e.g. A3 or X4) connected to SpeakON sockets (3) & (4). The acoustical cross-over frequency in this preset is approx. 120 Hz.

: **LP 160Hz + HP 160Hz:**

Preset with a higher cross-over frequency for use when the second and third amplifier channel are powering smaller mid-high systems (e.g. A1 or X1) connected to SpeakON sockets (3) & (4). The cross-over frequency in this preset is approx. 160 Hz.

: **LP 160Hz + HP 120Hz:**

Preset with a larger overlap range of the cross-over frequencies in connection with small to medium mid-high systems (e.g. A2 or X2) on the SpeakON sockets (3) & (4). The low-pass frequency from the internal subwoofer is approx. 160 Hz and the high-pass frequency from the top section is approx. 120 Hz. This setting is suitable when more low-mids are required.

AUX-MODE: **Switchable AUX mode:**

This function can be activated in the three presets mentioned above. When AUX mode is active, channel strip A (Signal In A – SpeakOn Out A socket (3)) operates as described in the loaded preset.

Channel strip B (Signal In B – SpeakOn Out B / AUX socket (4)) operates independently of channel strip A when the AUX mode is active. The signal is amplified unchanged (flat) and a protective high pass at 50 Hz is active. This channel can therefore be used as an independent amplifier channel (e.g. for monitor applications) for multifunction boxes / tops that do not require a controller setup.

5.4.2 Preset Bank 2 – L-series

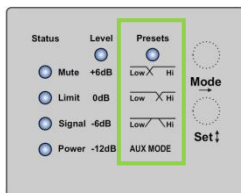

\overline{X} : LP 120Hz + L-series HP 180Hz:

Preset for use when the second and third amplifier channels are powering L16i/j systems connected to SpeakON sockets (3) & (4).

\overline{X} : LP 160Hz + L-series HP 180Hz:

Preset for use when the second and third amplifier channels are powering L8i/j or L16i/j systems connected to SpeakON sockets (3) & (4) and more low-mids are required.

$\overline{/ \ \backslash}$: LP 120Hz + L-series +Low:

Preset for use when the second and third amplifier channels are powering L8i/j or L16i/j systems connected to SpeakON sockets (3) & (4) with a level optimized low-mid range. The maximum achievable level of the mid-high unit is marginally reduced with this setting.

AUX-MODE: **Switchable AUX mode:**

See the description for Preset Bank 1.

5.4.3 Preset Bank 3 – i-/GL-series

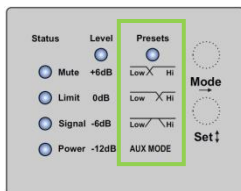

\overline{X} : LP 120Hz + i5:

Preset for use when the second and third amplifier channels are powering i5 systems connected to SpeakON sockets (3) & (4).

\overline{X} : LP 160Hz + i4:

Preset for use when the second and third amplifier channels are powering i4 systems connected to SpeakON sockets (3) & (4).

$\overline{/ \ \backslash}$: LP 120Hz + GL-series xov:

Preset for use when the second and third amplifier channels are powering GL systems (xov versions) connected to SpeakON sockets (3) & (4).

AUX-MODE: **Switchable AUX mode:**

See the description for Preset Bank 1.

5.5 Reprogramming of dp-speakers with preset audio files

By default, the built-in DSP controller is in a default configuration state that conforms to the description in the User Manual. The installation of special presets on the DSP controller can be done by the user himself, since only a special preset audio file must be loaded. The programming of these audio files via the LPI (Loudspeaker Programming Interface) can only be done by the manufacturer.

The preset is getting installed on the DSP by playing the preset audio file in the XLR input. This can be done in different ways (MP3 player, smart phone, PC, CD player, ...). Installation via PC is done as follows:

1. Use a mini-jack-XLR (stereo) cable to connect the headphone output to the XLR input of the self-powered box. Use only one of the XLR connectors.
2. Mute the box by pressing the Set button in Status Mode. The Mute LED lights up. The DSP controller can only receive data in the muted state.
3. Make sure your computer's volume is set to 100%.
4. Load the ".wav" file received from SEEBURG acoustic line into a music player.
5. Press the play button.
6. After a successful programming operation, the Mute LED turns off.



It is very important to ensure that the preset audio file is played in single mode. Other music files in the playlist or on the data storage medium will otherwise be played at full volume.

5.6 Locking the buttons

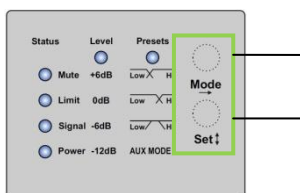

Press and hold the Set and Mode buttons simultaneously for more than 3 seconds to lock the controls of the system. Repeat the action to unlock the system.

6 Application examples

The following examples show usual setup variants and the associated settings. The mid-high units pictured here are to be regarded as universal loudspeakers. When using other mid-high units (e.g. L16 or GL24), it could be necessary to select the Preset Bank with the corresponding controller setups. An overview of the programmed Preset Banks can be found in section 5.2.

6.1 Application example 1

Preset Bank	1 – 3, depends on the used mid-high system
Level	Adjustment of the subwoofer level to the size/level of the mid-high units according to your own discretion. (Depends on music genre and spatial conditions, etc.)
Preset	1 – 3, depends on the used mid-high system
AUX mode	inactive

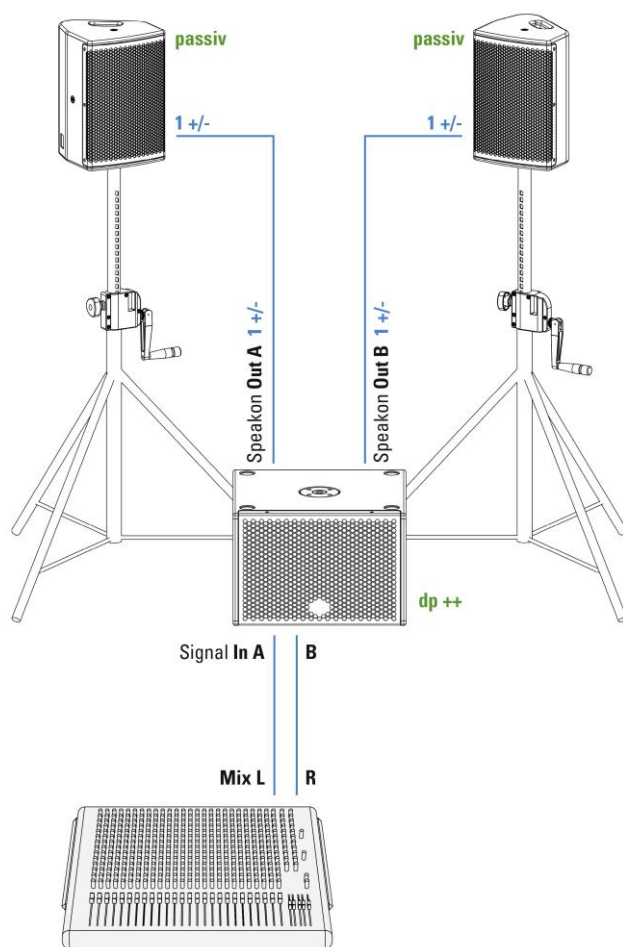

* passiv (dt.) \triangleq passive (engl.)

6.2 Application example 2

Preset Bank	1 – 3, depends on the used mid-high system
Level	Adjustment of the subwoofer level to the size/level of the mid-high units according to your own discretion. (Depends on music genre and spatial conditions, etc.)
Preset	1 – 3, Abhängig von den verwendeten Topteilen
AUX mode	inactive

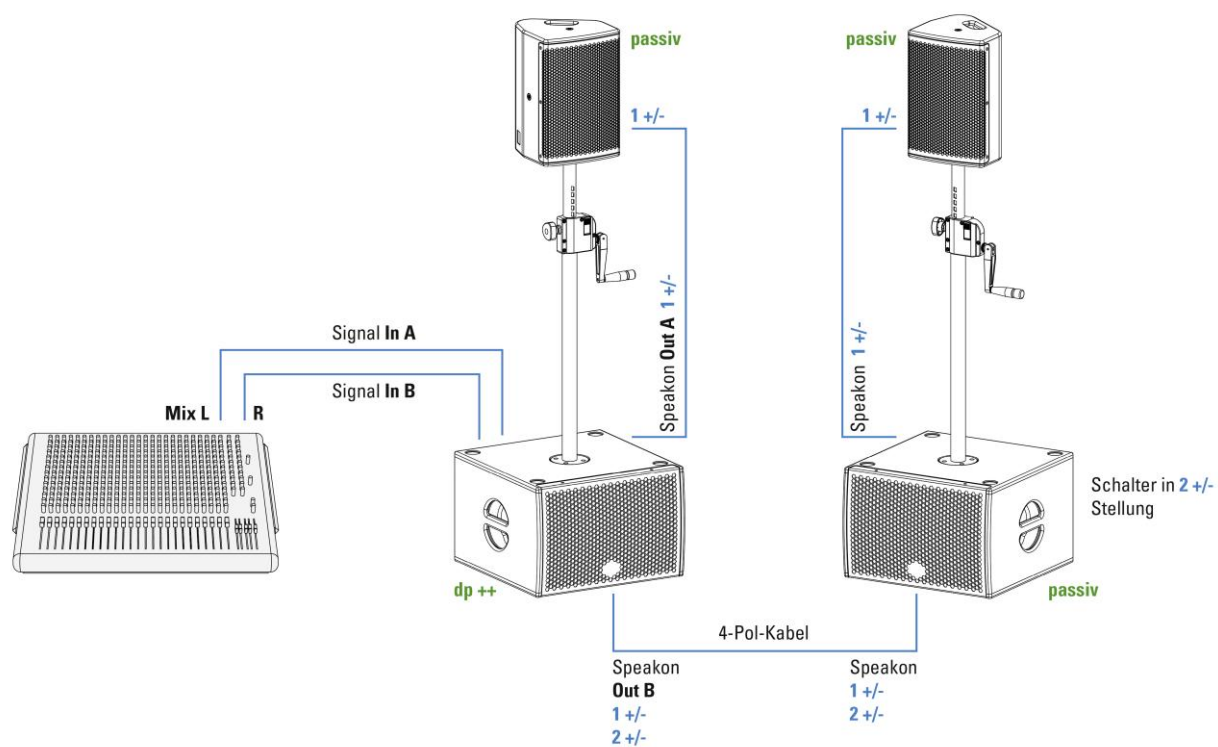

* 4-Pol-Kabel (dt.) \cong 4 pole cable (engl.)

* passiv (dt.) \cong passive (engl.)

6.3 Application example 3

Preset Bank	1 – 3, depends on the used mid-high system
Level	Adjustment of the subwoofer level to the size/level of the mid-high units according to your own discretion. (Depends on music genre and spatial conditions, etc.)
Preset	1 – 3, depends on the used mid-high system
AUX mode	active
General remarks	It should be absolutely ensured that both dp ++ subwoofers are set the same.

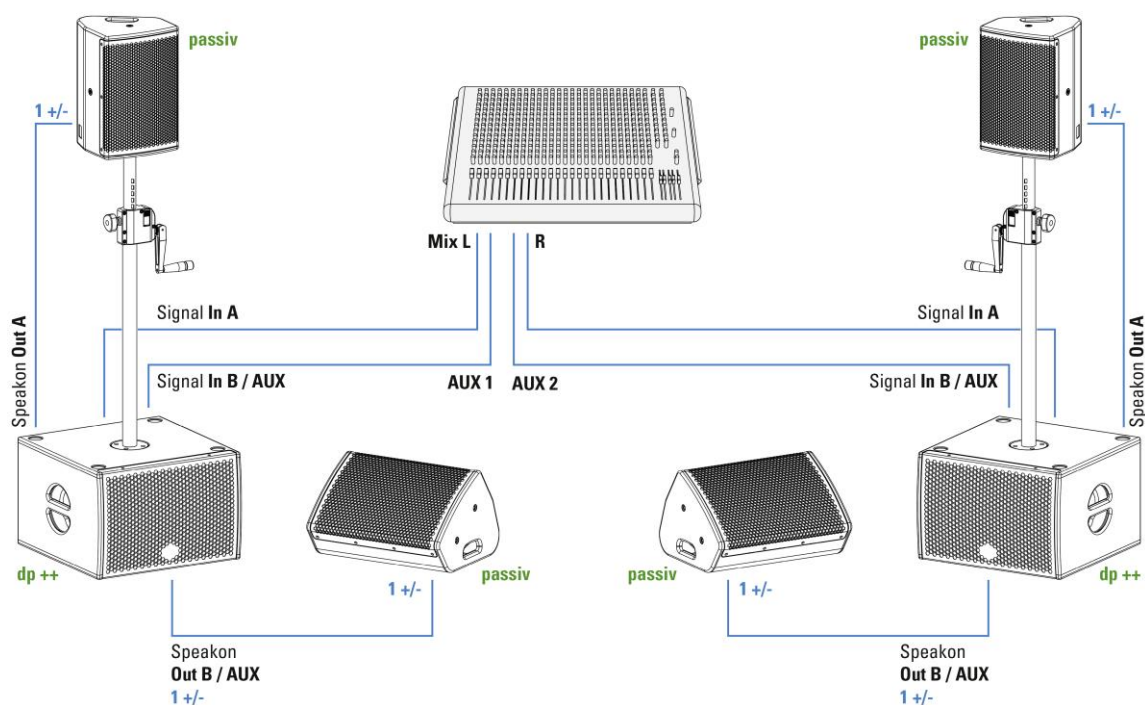

* passiv (dt.) $\hat{=}$ passive (engl.)

7 Technical specifications

Speaker Components	12" Nd (3" VC)
Description	Digitally Powered Bass Extension
Amp Power	500 W AES (single mode) / 110-230V 1000 W AES (dual mode) / 110-230V 2x 500 W AES / 4 Ω - HiMid
Rated Current	1,6 A @ 230 V
SPL (Peak @ 1m)	131 dB
Max. Input Signal	25 dBu
DSP	HDLM FPGA Processing 32 bit floating point
AD / DA	24 bit / 96 kHz
Latency	0,8 ms (analog in to analog out)
Usable Range (-6dB)	38 Hz - 220 Hz (-6dB)
Tuning Frequency Excursion minimum	47 Hz
Connectors	2x Neutrik XLR in Neutrik PowerCon in 2x Neutrik Speakon NL4MP out
Handles	2 x
Rigging / Fittings	M20 on top
Weight	17,5 kg
Size height x width x depth	33,0 x 48,5 x 48,5 cm
Order No.	00610/dp++

The technical data sheet and further information about possible applications for the system and available accessories can be downloaded at the following Internet address:

http://www.seeburg.net/download_getfile.php?file=downloads/06-Datenblaetter/G-Subwoofer/G-Sub-1201-dp-plus-plus_Datenblatt_dt.pdf

8 Declaration of conformity

EG Declaration of conformity

This product

G Sub 1201 dp++

confirms to the following EU guidelines, including any additions:

- ✓ 2006/95/EG, Low Voltage
- ✓ 2004/108/EG, Electromagnetic Compatibility
- ✓ (Locations: Appendix 1, Paragraph 1, a and b)

The following standards have been applied:

- ✓ DIN EN 60065
- ✓ DIN EN 55103-1:1996, classes E1 to E4
- ✓ DIN EN 55103-2:1996, classes E1 to E4

Declared by: Winfried Seeburg, SEEBURG acoustic line GmbH

Place and date: Senden, 01.01.2020

Legally binding sign: _____

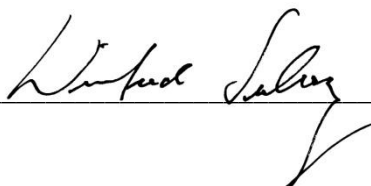

The attachments constitute part of this declaration. This declaration certifies conformity with the listed guidelines, but does not guarantee any product characteristics. The safety precautions listed in the product documentation must be observed.

SEEBURG acoustic line Produktions- und Vertriebsgesellschaft mbH

Auweg 32

89231 Senden

07307 / 9700 – 0

Benutzerhandbuch / User Manual

Irrtum bei Beschreibung
sowie technische
Änderungen vorbehalten.

Alle SEEBURG acoustic line
Produkte sind nur für den
gewerblichen Einsatz bestimmt.

All specifications are
current at the time of publishing
but are subject to change.

SEEBURG acoustic line
Produktions- und Vertriebs GmbH

Auweg 32
D-089250 Senden-Freudenegg

Fon: +49 (0)7307 97 00- 0
Fax: +49 (0)7307 97 00- 29

www.seeburg.com
info@seeburg.net